

RoHS

This products can apply to the HHB Doc NO. QA-3-04-005 of Environmental&Material Management Rules

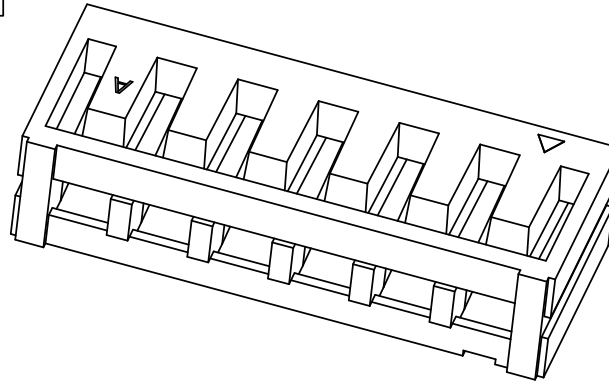

■ Specifications :

- Voltage rating: 250V AC / DC
- Current rating: 3A AC / DC
- Withstanding voltage: 800V AC/minute
- Temperature range: -40°C~+105°C
- Insulation resistance:≥1000MΩ
- Suitable HHB Terminal:J2509RT

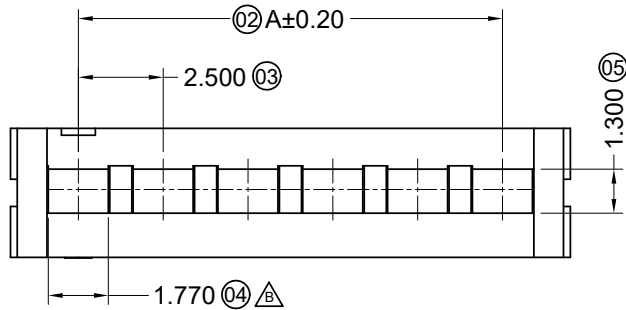
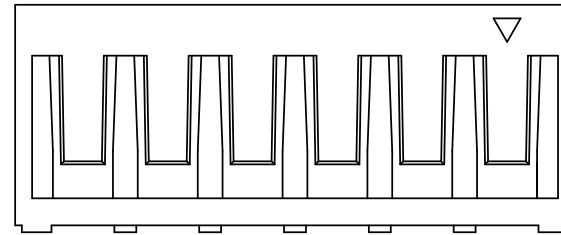
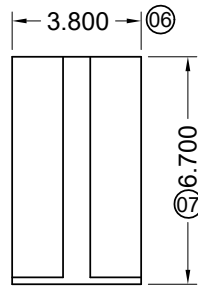
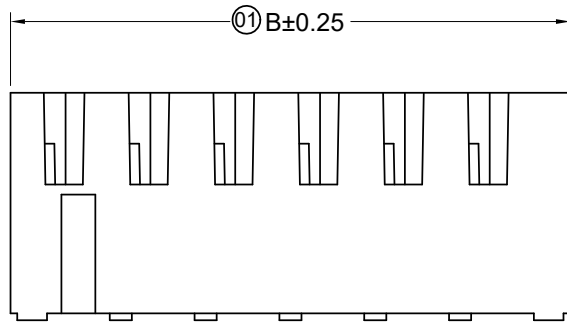
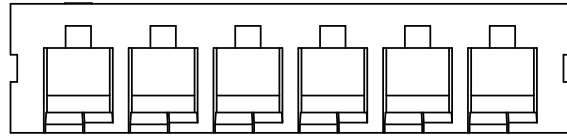

Poles	Dimensions (mm)		Poles	Dimensions (mm)	
	A	B		A	B
02	2.50	6.50	10	22.50	26.50
03	5.00	9.00	11	25.00	29.00
04	7.50	11.50	12	27.50	31.50
05	10.00	14.00	13	30.00	34.00
06	12.50	16.50	14	32.50	36.50
07	15.00	19.00	15	35.00	39.00
08	17.50	21.50	16	37.50	41.50
09	20.00	24.00			

2020/03/25	D	EN20200325001	Update Drawing Frame, The Same ECR And ECN NO	Zeng	Robing	东莞市翰皓精密电子有限公司 DONGGUAN HANHAO PRECISION ELECTRONIC CO.,LTD				PART NO. J2509HR-XX				
2020/01/08	C	EN20200108001	Add the LOGO and mold hole number according to the real object	Mandy	Robing					APPROVAL				TITLE 2.50mm Crimp Style Connectors
2019/07/12	B	ER20190712001	Optimization of products	Zeng	Robing	CHECK				UNIT				
DATE	REV	ECN NO.	DESCRIPTION	MODIFY	APPROVAL	DRAWN				SCALE				
						DATE				SHEET				
						PROJECT				REV				
						Robing				NUMBER				
						Joshua				mm				
						Jason				1:1				
						2018/08/16				1/1				
										D				
										A-022				

RoHS

This products can apply to the HHB Doc NO. QA-3-04-005 of Environmental&Material Management Rules

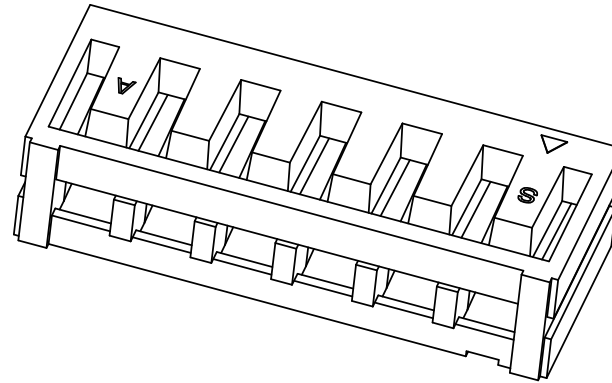
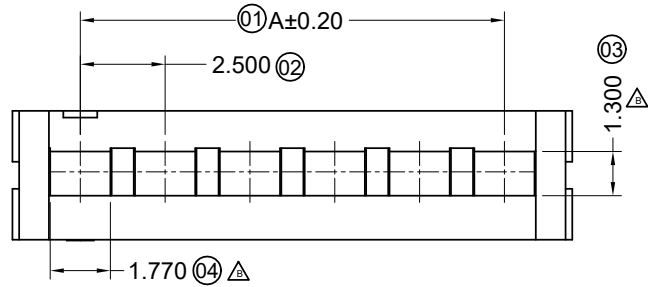

- Specifications :
- Voltage rating: 250V AC / DC
 - Current rating: 3A AC / DC
 - Withstanding voltage: 800V AC/minute
 - Temperature range: -40°C~+105°C
 - Insulation resistance:≥1000MΩ
 - Suitable HHB Terminal:J2509VT

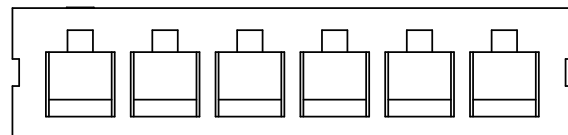
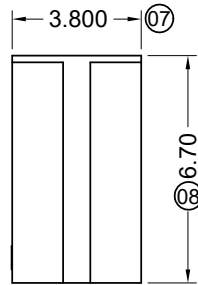
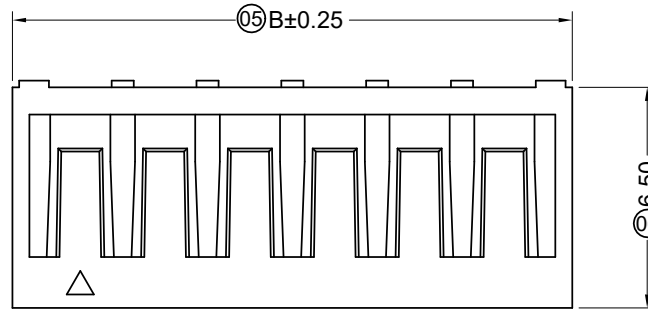

Poles	Dimensions (mm)		Poles	Dimensions(mm)	
	A	B		A	B
02	2.50	6.50	10	22.50	26.50
03	5.00	9.00	11	25.00	29.00
04	7.50	11.50	12	27.50	31.50
05	10.00	14.00	13	30.00	34.00
06	12.50	16.50	14	32.50	36.50
07	15.00	19.00	15	35.00	39.00
08	17.50	21.50	16	37.50	41.50
09	20.00	24.00			

2020/03/25	D	EN20200325001	Update Drawing Frame, The Same ECR And ECN NO	Zeng	Robing	东莞市翰皓精密电子有限公司 DONGGUAN HANHAO PRECISION ELECTRONIC CO.,LTD				PART NO. J2509HV-XX				
2020/01/08	C	EN20200108001	Add the LOGO and mold hole number according to the real object	Mandy	Robing					APPROVAL				TITLE 2.50mm Crimp Style Connectors
2019/07/12	B	ER20190712001	Optimization of products	Zeng	Robing	CHECK				UNIT	SCALE	SHEET	REV	NUMBER
DATE	REV	ECN NO.	DESCRIPTION	MODIFY	APPROVAL	DRAWN				mm	1:1	1/1	D	A-022
						DATE								
						Robing								
						Joshua								
						Yu wei								
						2018/08/16								

RoHS

This products can apply to the HHB Doc NO. QA-3-04-005 of Environmental&Material Management Rules

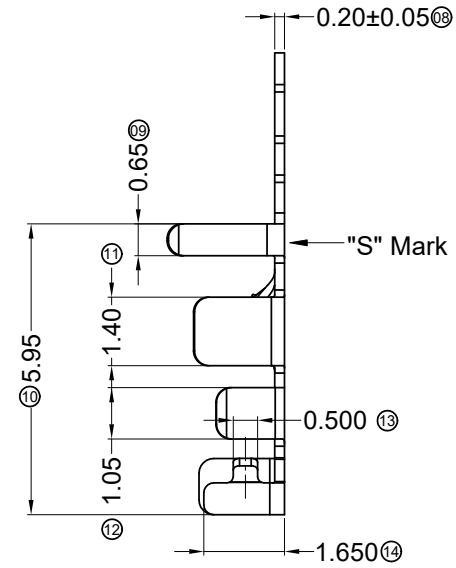
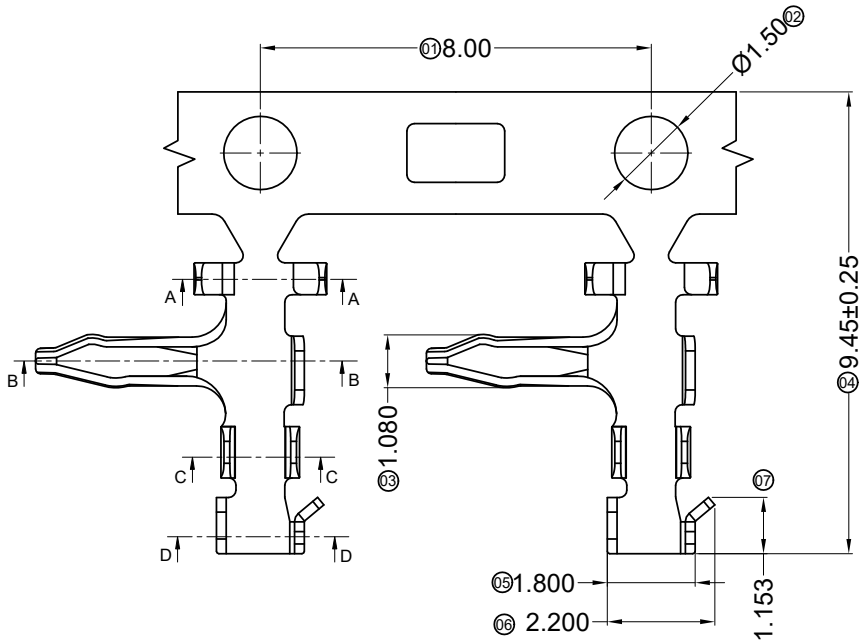

- Specifications :
- Voltage rating: 250V AC / DC
 - Current rating: 3A AC / DC
 - Withstanding voltage: 800V AC/minute
 - Temperature range: -40°C~+105°C
 - Insulation resistance:≥1000MΩ
 - Wire Size:AWG#22~24(0.35~0.22mm²)
 - Insulation O.D.:1.60mm (Max)
 - Used In HHB Housing:J2509HR-XX

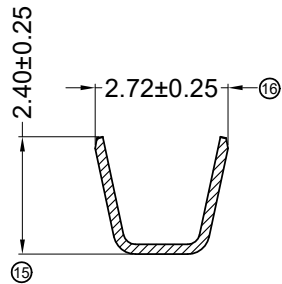

SECTION A-A
SCALE 1:1

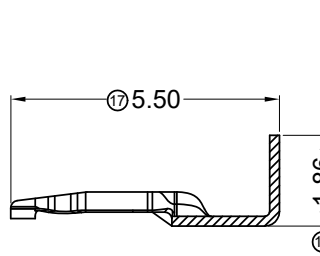

SECTION B-B
SCALE 1:1

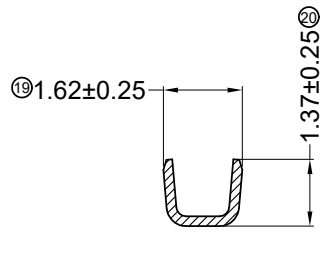

SECTION C-C
SCALE 1:1

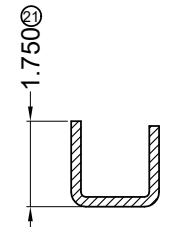

SECTION D-D
SCALE 1:1

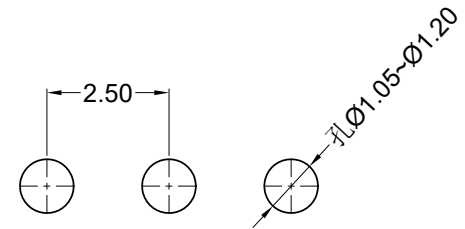

Recommended P.C.B Layout
General Tolerance±0.05 T=1.60mm

					GENERAL TOLERANCE				东莞市翰皓精密电子有限公司 DONGGUAN HANHAO PRECISION ELECTRONIC CO.,LTD				PART NO.				
					.X	±0.30	.XX	±0.20					.XXX	±0.10	X.°	±2°	J2509RT
					PROJECT				APPROVAL	CHECK	DRAWN	DATE	TITLE				
					Roving				Joshua	Jason	2018/08/16	2.50mm Crimp Style Connectors					
DATE	REV	ECN NO	DESCRIPTION	MODIFY	APPROVAL					UNIT	SCALE	SHEET	REV	NUMBER			
2020/03/25	C	EN20200325001	Update Drawing Frame, The Same ECR And ECN NO	ZW	ROBING					mm	1:1	1/1	C	A-014			
2019/07/12	B	ER20190712001	Optimization of products	ZW	ROBING												

